

SOLAR 160 WV

Operating Weight: 14.400 ~ 15.900 kg

Bucket capacity (SAE): 0,28 ~ 0,75 m³

Engine Power: 96 kW (128 Hp) / 2.200 rpm



www.doosaninfracore.com

DOOSAN DAEWOO

Performance

This hydraulic excavator is equipped with the air-to-water intercooler engine, which has the greatest power output in its class and excellent fuel economy. It assures outstanding workability, productivity, and efficiency through the e-EPOS system, the new and improved version of EPOS System. This will assure increase in operating capacity and decrease in fuel consumption.



Joystick grip with 3 switches

Spare switches are installed on both joystick grips to control the additional attachment.

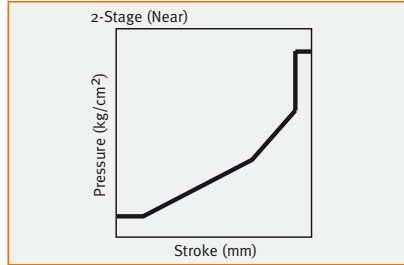

Improved manoeuvrability and control

New technologically advanced control valve and joystick valves have been installed to allow speedy, smooth and responsive control.



Air-to-water intercooler engine

Greatest power output and high-efficiency engine in its class.



Environmentally friendly, Green engine

This machine is equipped with the engine meeting the U.S. EPA Tier-II Regulations and European stage-II.



Excellent Reliability

DOOSAN's world-class center for product reliability performs sophisticated testing on all completed products, to ensure they meet or exceed market standards.



Vertically mounted transmission

The transmission has been mounted vertically to increase ground clearance of the travel motor. It ensures the travel motor when travel terrible work field.

Heat shield panel for turbo charger

The heat shield guard has been installed over the turbo charger to prevent the operator from inadvertently touching the hot surfaces while checking the engine area.



Working Environment

Wide operator cabin space meeting the ISO Standards and expanded all-round visibility. The low-noise, low-vibration type comfortable cabin provides the operator with safe and ergonomic operating environment.



The handle with tilting function

Because the handle with tilting function can be adjustable forward & backward according to operator's figure & location. The best operation & always minimum operator's fatigue in the optimum condition.

Increased foot space

Instruments, controls, and accessories have been ergonomically located in the cabin and 300mm seat slide has been achieved to provide ample space for operator's feet and legs.

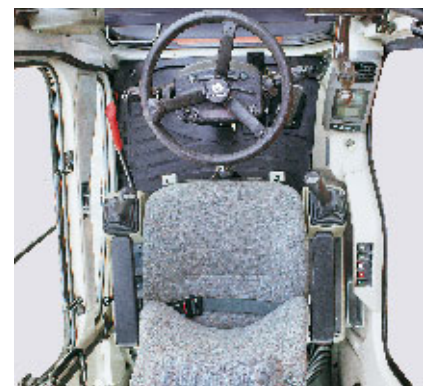

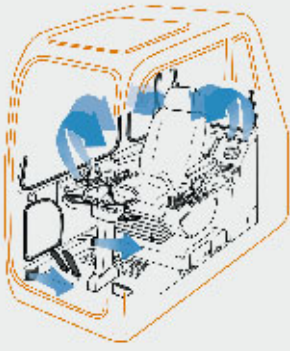

Fresh Air Type Air Conditioner

One touch selector switch for the air conditioner and heater output, featuring a multivent circulation system that allows for greater cooling / heating performance. Improved front window defroster system has been added to provide enhanced clarity and visibility during any working condition.

- Easy replaceable air filter
- Larger cool air intake vents
- Industry standard fresh air/recirculation control system incorporated
- Modular electric fan condenser compartment

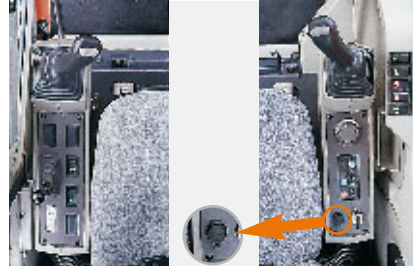

Cup holder

A folding style cup holder has been installed in the cabin allowing the operator to easily store a can or cup.

12 V Spare Power Socket

This socket can be used for charging a cellular phone or powering a small 12 V DC electrical device.

Low Vibration Cab Mounting System

By using a total isolating seal design (full sealing) outside noise has been drastically reduced to the levels comparable to that in a modern car. A viscous sealed mounting system has been incorporated, and the frame, cabin and seat have been designed to absorb major and minor vibrations, resulting in a significant decrease in vibration felt by the operator.

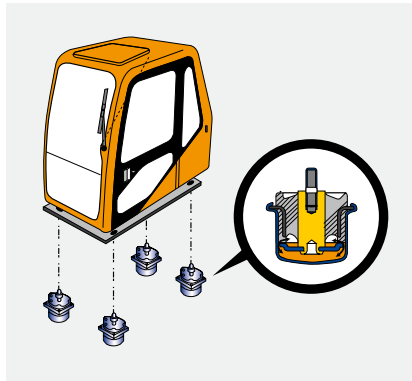

Long wind shield wiper blade

Front visibility is further improved by using the lengthened wiper blade.

Large ceiling cover

The ceiling cover can be opened to confirm the bucket operation even at the maximum excavating height.



Maintenance

Quick and easy service checks, maximizing the excavator's life expectancy.



Water separator

The transparent glass water separator is mounted at a location easily accessible from the ground allowing easy maintenance of the fuel system.



Electrical control access box

Pull-out style drawer for electrical control access box allows for easy service and maintenance.



PC monitoring function (SMS)

By connecting a laptop PC to the controller (e-EPOS controller) of the machine, data such as pump pressure and engine RPM can be displayed graphically. Also other various machine status data can be stored in memory and printed out using a printer.



Large fuel tank

The fuel tank with 230 liter capacity has been mounted to increase filling up interval.

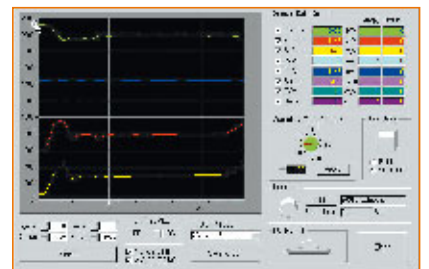

All range fuel level gauge

The fuel level gauge which shows the fuel through all range is installed on the side of the fuel tank.

Engine oil drain valve

The engine oil drain valve with quick coupler provides fast and environmentally sound serviceability.



GRAPHIC DISPLAY LCD MONITOR PANEL

The information monitor panel displays both text and symbols for easy recognition of machine status and various other data.

SIMPLIFIED OPERATION MODE SELECTION

The 3 work modes from the previous models have been reduced to digging and trenching modes for easy selection.

Digging Mode :

General Excavating, Ground Leveling, Loading Dump Truck, allows for versatility.

Trenching Mode :

trenching or excavating of side wall, operations which require heavy swing work.

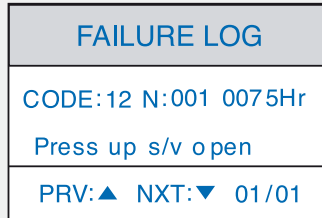

Self-diagnosis and fault history memory functions

Current faults and past faults history of the excavator control system are displayed and memorized on a real-time basis to enable correct diagnosis and quick repair.



Real-time clock with day / date

The real-time clock displays date and day in easy to read format.



Filter / oil operating hour display

The hours in use for 9 filters and oils can be displayed so that replacement intervals can be easily recognized.

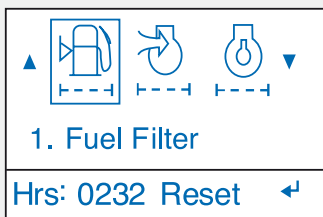

Multiple language display

The user menu can be displayed in multiple languages for the operator's convenience.

Real-time machine data display

Displays 28 different machine status data and information such as pump delivery pressure and engine RPM.

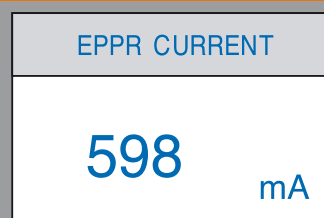

Technical Data



ENGINE

MODEL

DOOSAN DB58TIS

TYPE

Water-cooled, 4-cycle, 6-cylinder in line, direct injection chamber type diesel engine. Air-to-water intercooler.

RATED FLYWHEEL HORSE POWER

DIN 6271, net 96 kW (130 Ps)
at 2.200 rpm
SAE J1349, net 96 kW (128 Hp)
at 2.200 rpm

PISTON DISPLACEMENT

5.785 cc

MAXIMUM TORQUE

50 kgf.m (490 Nm) at 1.600 rpm

BORE AND STROKE

102 x 118 mm

STARTING SYSTEM

24 V electric motor

BATTERIES

2 x 12 V x 100 Ah

AUTO-IDLE SYSTEM

Engine rpm is reduced automatically to the low idle rpm after a lapse of approx. 4 seconds with all control levers in neutral position, thus saving energy and reducing noise.



HYDRAULIC SYSTEM

DOOSAN's e-EPOS (Electronic Power Optimizing System) can achieve maximum job efficiency and reduce fuel consumption.

- 2-power mode working system
- 2-Working mode selection system
- Computer aided engine pump control
- Hydraulic system assures fully independent and combined operations
- Cross-sensing and fuel saving pump system
- Auto idle system
- 2 speed travel system for high traction force and travel speed
- Travel motor brake torque-up system
- Cruise travel system

MAIN PUMPS

2 variable displacement axial piston pumps.

Max. oil flow 2 x 162 l/min

PILOT PUMP

Gear pump
Max. oil flow 22 l/min
Pressure setting 39 bar

BRAKE PUMP

Gear pump
Max. oil flow 14,3 l/min
Pressure setting 157 bar

STEERING PUMP

Gear pump
Max. oil flow 28 l/min
Pressure setting 167 bar

MAIN RELIEF VALVES

Boom/Arm/Bucket 343 bar
Travel circuit 343 bar

OVERLOAD RELIEF VALVES

Boom circuit 353 bar
Arm circuit 353 bar
Bucket circuit 353 bar

SWING MOTOR RELIEF VALVE

265 bar



HYDRAULIC CYLINDERS

High-strength piston rods and tubes are used. Cylinder cushion mechanism is provided for boom, articulated boom. Arm and bucket cylinders to assure shock-free operation and extend life of cylinder.

MONO BOOM

Cylinders	Q'ty	Bore x Rod dia. x Stroke
Boom	2	110 x 75 x 1.030 mm
Arm	1	110 x 75 x 1.085 mm
Bucket	1	95 x 65 x 885 mm

ARTICULATED BOOM

Cylinders	Q'ty	Bore x Rod dia. x Stroke
Boom	2	110 x 75 x 935 mm
Arti.Boom	1	180 x 115 x 600 mm
Arm	1	115 x 80 x 1.085 mm
Bucket	1	95 x 65 x 885 mm



SUPER-STRUCTURE REVOLVING FRAME

A deep, full-reinforced box section. Heavy-gauge steel plates used for ruggedness.



OPERATOR'S CAB

Independent, shock and noise-free roomy ISO standard operator's cab. 4 side safety glass windows give all-round visibility. Front window slides up and stores in the roof. Left and right side windows opens for ventilation. Fully adjustable reclining seat fwd./rev. and up/down. Cab cooler is optionally available.



CONTROLS 2 IMPLEMENT LEVERS

Pilot pressure control type. Right lever is for boom and bucket control, left lever for swing and arm control. Left rear lever is for dozer and outrigger. Left bottom pedal is for articulated boom.

NOISE LEVELS (DYNAMIC VALUE)

LwA external noise:

102 dB (A) (2000/14/EU)

LpA operator noise:

75 dB (A)

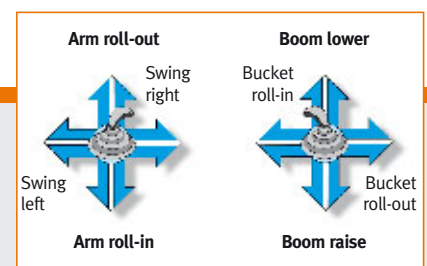



SWING MECHANISM

High-torque, axial piston motor with planetary reduction gear bathed in oil. Swing circle is a single-row, shear type ball bearing with induction-hardened internal gear. Internal gear and pinion immersed in lubricant. Swing reactionless valve is internally attached. Spring applied hydraulically released parking brake.

A swing lock clamps the superstructure for transportation.

SWING SPEED

0 to 12,5 rpm

REAR SWING RADIUS

2.210 mm



DRIVE

Fully hydrostatic driven, 2 speed power shift transmission, variable displacement, high torque, axial piston motor, foot pedal controls provide smooth travel, hub reduction type front steering axle and rear rigid axle.

TRAVEL SPEED

0 to 37 km/h

A maximum speed restriction of 20 km/h is available as an option.

MAXIMUM TRACTIVE FORCE

Force 8.182 kgf

Gradeability 35° (70%) continuous



UNDERCARRIAGE

Heavy-duty frame, all-welded stress-relieved structure. Top grade materials used for toughness. Specially heat-treated connecting pins. 10.00-20-14PR(OTR) double tires with tire spacer. Front axle oscillating hydraulically.



BRAKE

Full sealed wet discs service brakes operated fully hydraulic and full sealed wet discs parking brake operated hydraulically.



WEIGHT

MAJOR COMPONENT WEIGHT (KG)

Mono boom : 4.600 mm (including cylinders and links)	1.450
Arti boom (including cylinders and links)	1.620
Arm : 2.100 mm	356
Arm : 2.500 mm	407
Front bucket cradle	100
Dozer blade (including cylinders)	650
Outriggers (including cylinders & frame)	850



SERVICE REFILL CAPACITIES (liters)

Fuel tank 230
Cooling system 31

LUBRICATION

Engine oil 19
Swing drive 2
Final drive (each) 4 x 1,25
Hydraulic tank 168
Front axle case 7,2
Rear axle case 7,5

EXAMPLES OF WEIGHT (10% FUEL INCLUDED)

Mono boom (4.600 mm) - Arm (2.500 mm) - Bucket 0,58 m³ SAE - Front dozer - Rear outriggers	14.450 kg
Arti boom - Arm (2.500 mm) - Bucket 0,58 m³ SAE - Front dozer - Rear outriggers	14.620 kg



BUCKETS

CAPACITY		WIDTH		WEIGHT	RECOMMENDATION	
SAE, heaped	CECE, heaped	Without side cutters	With side cutters		4,6 m Boom	
				2,1 m	2,5 m	
0,28 m ³	0,25 m ³	550 mm	650 mm	330 kg	A	A
0,39 m ³	0,35 m ³	760 mm	860 mm	380 kg	A	B
0,51 m ³	0,45 m ³	950 mm	1.050 mm	430 kg	B	C
0,58 m ³	0,50 m ³	1.040 mm	1.140 mm	450 kg	C	X
0,64 m ³	0,55 m ³	1.120 mm	1.220 mm	475 kg	X	X
0,75 m ³	0,65 m ³	1.300 mm	1.400 mm	520 kg	X	X

A. Suitable for materials with density of 2.000 kg/m³ or less

B. Suitable for materials with density of 1.600 kg/m³ or less

C. Suitable for materials with density of 1.100 kg/m³ or less

Undercarriage

UNDERCARRIAGE WITH FRONT CRADLE AND REAR DOZER

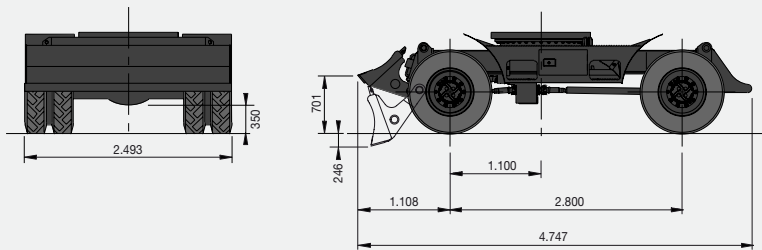

UNDERCARRIAGE WITH 2 SETS OF OUTRIGGERS

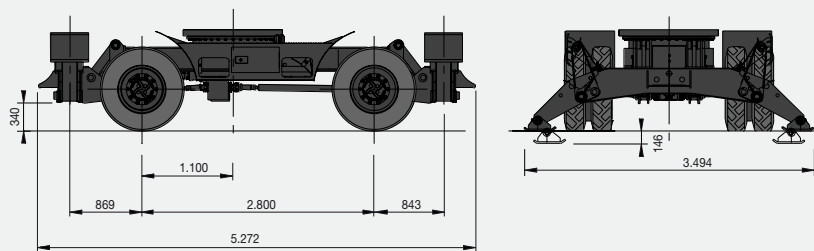

UNDERCARRIAGE WITH FRONT DOZER AND REAR OUTRIGGERS

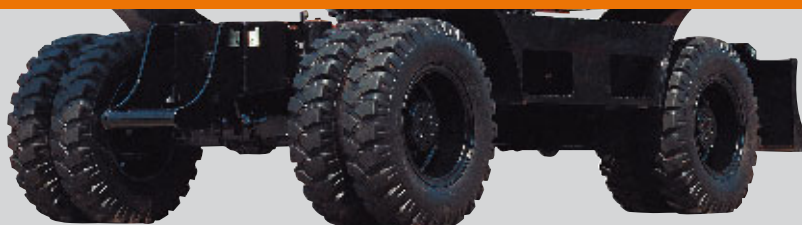
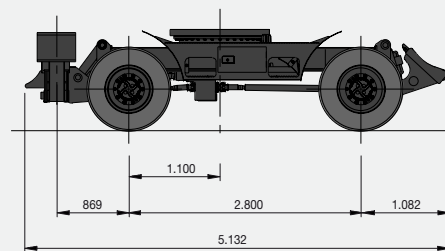

Standard & Optional Equipment

STANDARD EQUIPMENT

HYDRAULIC SYSTEM

- Boom and arm flow regeneration
- Boom and arm holding valves
- Swing anti-rebound valves
- Spare ports (valve)
- One-touch power boost
- Piping for hammer (one way)

CABIN & INTERIOR

- Viscous cab mounts
- All weather sound suppressed type cab
- Air conditioner
- Adjustable suspension seat with head rest and adjustable arm rest
- Pull-up type front window and removable lower front window
- Room light
- Intermittent windshield wiper
- Cigarette lighter and ashtray
- Cup holder
- Hot & cool box
- Graphic display monitor
- Fuel control dial
- AM/FM Radio and cassette player
- Remote radio ON/OFF switch
- 12V spare power socket
- Serial communication port for laptop PC interface
- Joystick lever with 3 switches

SAFETY

- Large handrails and step
- Punched metal anti-slip plates
- Seat belt
- Hydraulic safety lock lever
- Safety glass
- Hammer for emergency escape
- Right and left rearview mirrors
- Boom and arm hose rupture protection valve

OTHERS

- Double element air cleaner
- Pre-cleaner
- Water separator
- Dust screen for radiator
- Engine overheat prevention system
- Engine restart prevention system
- Self-diagnostic system
- Alternator (24 V, 50 A)
- Electric horn
- Halogen working lights (frame mounted 2, boom mounted 2)
- Electric fuel supply pump
- Front dozer blade
- Rear stabilizer

OPTIONAL EQUIPMENT

SAFETY

- Overload warning device
- Cabin Top/Front guard (FOGS standard)
- Travel alarm
- Travel & swing alarm
- Rotating beacon

CABIN & INTERIOR

- Sunvisor
- Sun roof

OTHERS

- Piping for rotation
- Double fuel filter
- Additional work lights on the cabin
 - 2 front lamps
 - 4 front and 2 rear lamps
- Large capacity alternator (24 V, 80 A)
- Rear dozer blade
- Front stabilizer
- Front cradle

Boom and arm hose rupture protection valve



Sunvisor

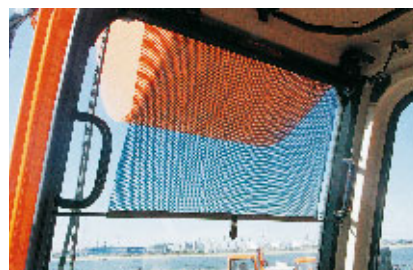

Additional work lights on the cabin



Electric fuel supply pump



Rotating beacon



Dimensions & Working Ranges

MONO BOOM

DIMENSIONS

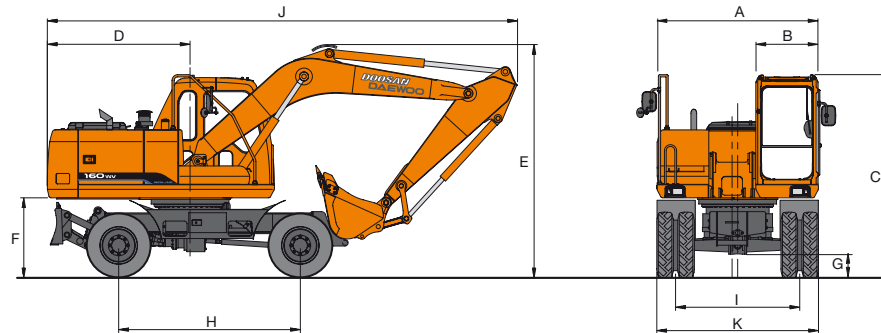

A	Overall width of upper structure	2.494 mm
B	Overall width of cab	960 mm
C	Overall height of cab	3.116 mm
D	Tail swing radius	2.210 mm
E	Overall height of boom	
	Arm length (3,0 m)	4.124 mm
	Arm length (2,5 m)	3.962 mm
	Arm length (2,1 m)	3.270 mm
F	Clearance under counterweight	1.241 mm
G	Ground clearance	350 mm
H	Wheel base	2.800 mm
I	Tread	1.914 mm
J	Overall length	
	Arm length (3,0 m)	7.232 mm
	Arm length (2,5 m)	7.290 mm
	Arm length (2,1 m)	7.665 mm
K	Overall tire width with fender	
	10.00-20-14PR Double tire (Std)	2.496 mm

WORKING RANGES

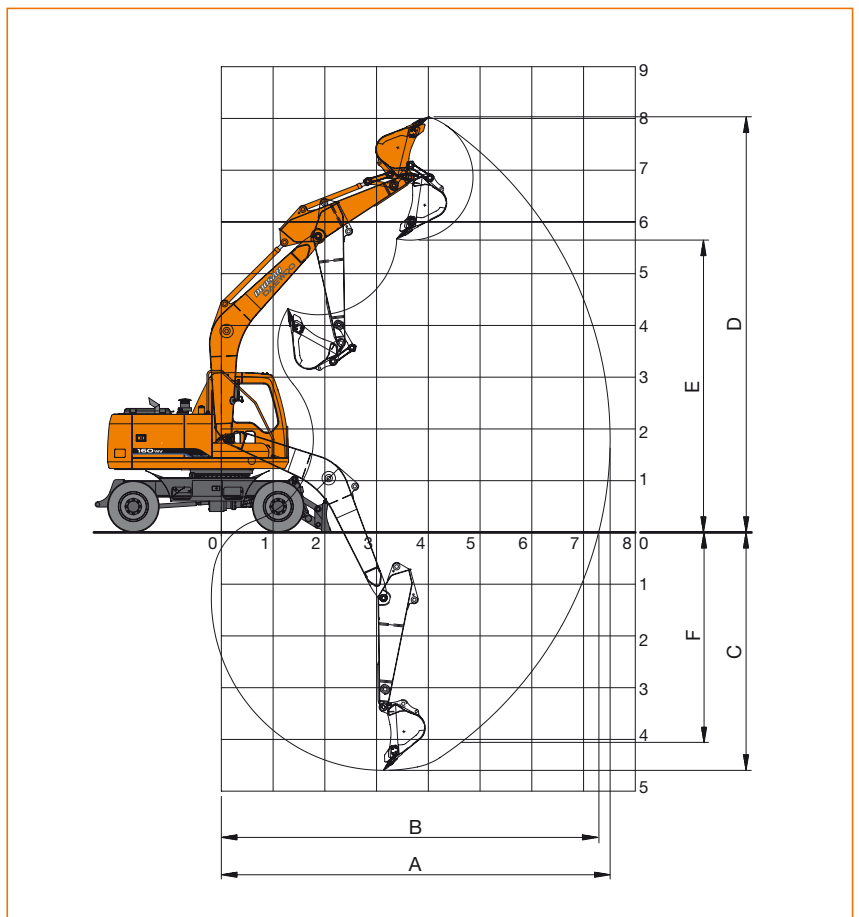

DIGGING FORCES

(MAXIMUM RADIAL TOOTH FORCES)

		2,1 m	2,5 m	3,0 m
Bucket digging force *	kgf	8.338	8.338	8.338
	kN	81,8	81,8	81,8
Arm digging force *	kgf	6.652	6.298	5.383
	kN	65,2	61,85	52,8

* At power boost

Boom length	4,6 m		
Arm length	2.100 mm	2.500 mm	3.000 mm

A. Max. digging reach	7.790 mm	8.208 mm	8.720 mm
B. Max. digging reach at ground level	7.580 mm	8.009 mm	8.400 mm
C. Max. digging depth	4.655 mm	5.056 mm	5.513 mm
D. Max. digging height	8.222 mm	8.565 mm	9.009 mm
E. Max. dumping height	5.849 mm	6.170 mm	6.596 mm
F. Max. vertical wall digging depth	4.228 mm	4.826 mm	5.200 mm

ARTICULATED BOOM

DIMENSIONS

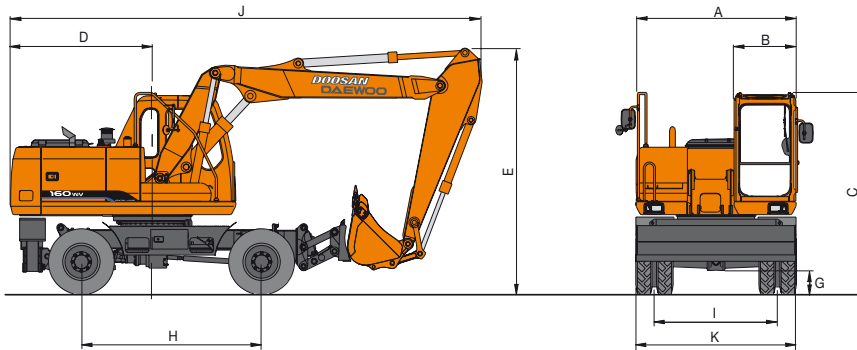

A Overall width of upper structure	2.494 mm
B Overall width of cab	960 mm
C Overall height of cab	3.116 mm
D Tail swing radius	2.210 mm
E Overall height of boom	
Arm length (2,5 m)	3.824 mm
Arm length (2,1 m)	3.824 mm
F Clearance under counterweight	1.241 mm
G Ground clearance	350 mm
H Wheel base	2.800 mm
I Tread	1.914 mm
J Overall length	
Arm length (2,5 m)	6.661/7.239 mm
Arm length (2,1 m)	6.687 mm
K Overall tire width with fender	
10.00-20-14PR Double tire (Std)	2.496 mm

WORKING RANGES

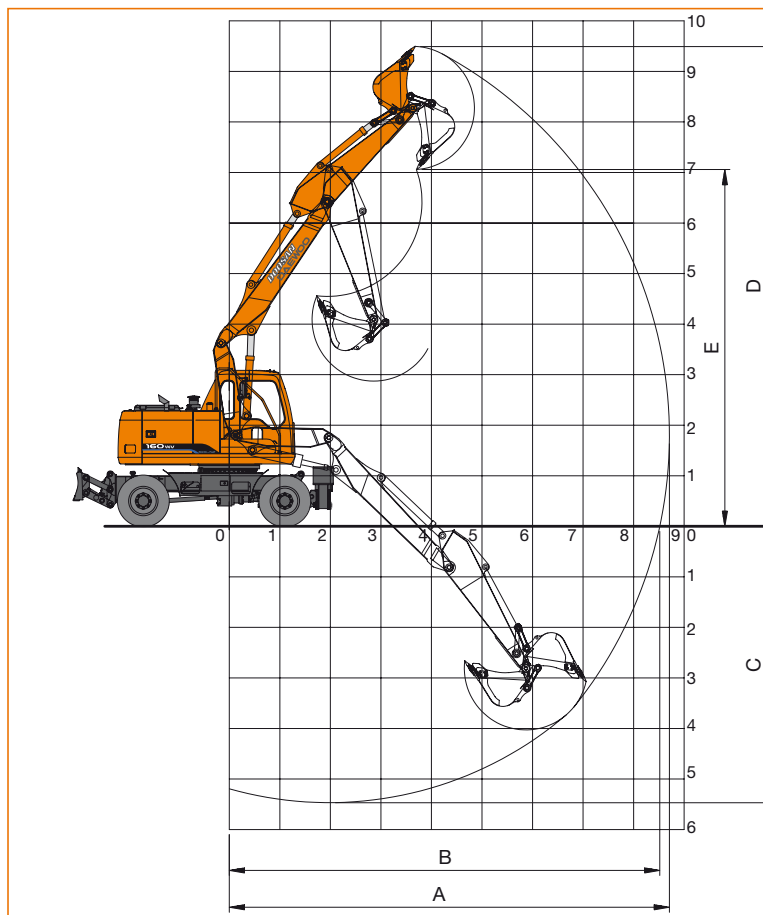

DIGGING FORCES

(MAXIMUM RADIAL TOOTH FORCES)

		2,1 m	2,5 m
Bucket digging force *	kgf	8.338	8.338
	kN	81,8	81,8
Arm digging force *	kgf	6.652	6.298
	kN	65,2	61,85

* At power boost

Arti boom

Arm length	2.100 mm	2.500 mm
-------------------	-----------------	-----------------

A. Max. digging reach	8.287 mm	8.708 mm
B. Max. digging reach at ground level	8.090 mm	8.521 mm
C. Max. digging depth	5.074 mm	5.483 mm
D. Max. digging height	9.096 mm	9.481 mm
E. Max. dumping height	6.663 mm	7.044 mm

Lifting Capacities

Mono Boom

STANDARD

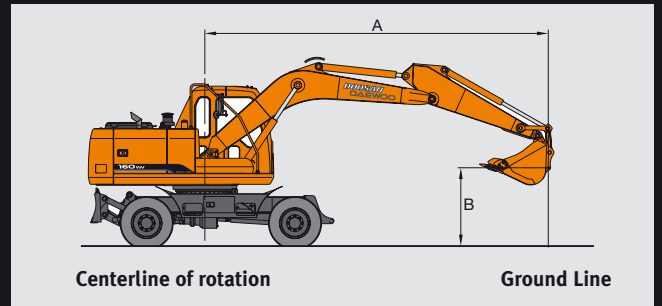

Boom : 4,6 m
Arm : 2,5 m
Bucket : SAE 0,58 m³ (CECE 0,55 m³)
Unit : 1.000 kg
Lifting conditions : Free on wheels / Dozer blade or Outriggers on ground

A(m)	2		3		4		5		6		7		8		Max. Reach		A(m)	
	□	□	□	□	□	□	□	□	□	□	□	□	□	□	□	□		
B(m)	6						*2,73/*2,73	*2,73/*2,73								*1,77/*1,77	*1,77/*1,77	5,91
	5						*3,12/*3,12	2,95/*3,12	*2,59/*2,59	2,18/*2,59						*1,75/*1,75	*1,75/*1,75	6,51
	4						*3,70/*3,70	2,89/*3,70	*3,19/*3,19	2,15/*3,19						*1,79/*1,79	1,68/*1,79	6,92
	3		*7,41/*7,41	6,21/*7,41	*5,82/*5,82	3,96/*5,82	*4,87/*4,87	2,80/*4,87	*3,89/*3,89	2,10/3,68						*1,87/*1,87	1,56/*1,87	7,16
	2		*9,39/*9,39	5,84/*9,39	*6,82/*6,82	3,78/*6,82	5,32/*5,51	2,71/4,84	3,93/*4,73	2,05/3,62						*1,99/*1,99	1,50/*1,99	7,25
	1		*7,85/*7,85	5,59/*7,85	*7,59/*7,59	3,64/6,83	5,21/*5,97	2,62/4,74	3,88/*4,97	2,00/3,57						*2,18/*2,18	1,50/*2,18	7,21
	0		*7,13/*7,13	5,47/*7,13	7,56/*7,94	3,55/6,71	5,14/*6,21	2,56/4,67	3,83/*5,08	1,96/3,52						*2,46/*2,46	1,55/*2,46	7,02
	-1		*8,25/*8,25	5,44/*8,25	7,51/*7,86	3,51/6,66	5,10/*6,16	2,53/4,63	3,81/*4,97	1,94/3,50						*2,89/*2,89	1,66/*2,89	6,67
	-2		*9,59/*9,59	5,46/*9,59	*7,33/*7,33	3,51/6,67	5,10/*5,75	2,53/4,63	3,82/*4,47	1,95/3,51						*3,64/*3,64	1,89/3,39	6,14
-3		*8,06/*8,06	5,53/*8,06	*6,24/*6,24	3,55/6,24	*4,77/*4,77	2,57/4,68								*4,20/*4,20	2,32/4,19	5,38	

OPTION

Boom : 4,6 m
Arm : 2,1 m
Bucket : SAE 0,58 m³ (CECE 0,55 m³)
Unit : 1.000 kg
Lifting conditions : Free on wheels / Dozer blade or Outriggers on ground

A(m)	2		3		4		5		6		7		8		Max. Reach		A(m)	
	□	□	□	□	□	□	□	□	□	□	□	□	□	□	□			
B(m)	6						*2,88	*2,88								*2,40	*2,40	5,27
	5						*3,75	*3,75								*2,41	*2,41	5,94
	4					*5,32	*5,32	*4,67	*4,67	*3,43	*3,43					*2,49	*2,49	6,39
	3			*8,30	*8,30	*6,32	*6,32	*5,30	4,95	*4,40	3,70					*2,64	*2,64	6,65
	2			*10,08	*10,08	*7,23	6,98	*5,79	4,85	*4,93	3,65					*2,88	*2,88	6,75
	1			*7,27	*7,27	*7,83	6,82	*6,15	4,76	*5,11	3,60					*3,23	3,05	6,70
	0		*3,55	*3,55	*7,63	*7,63	*8,01	6,73	*6,28	4,70	*5,13	3,57				*3,76	3,17	6,50
	-1		*5,48	*5,48	*9,42	*9,42	*7,74	6,70	*6,10	4,68	*4,86	3,56				*4,66	3,46	6,12
	-2		*7,70	*7,70	*9,01	*9,01	*7,01	6,73	*5,50	4,70						*4,75	4,03	5,54
-3		*9,14	*9,14	*7,21	*7,21	*5,64	*5,64								*4,63	*4,63	4,67	

Note 1. Ratings are based on SAE J1097
 2. Load point is the hook on the back of the bucket
 3. * = Rated loads are based on hydraulic capacity
 4. Rated loads do not exceed 87% of hydraulic capacity or 75% of tipping capacity

□ : Rating over front
 □ : Rating over side or 360 degree
 ○ : Ground

ARTICULATED BOOM

STANDARD

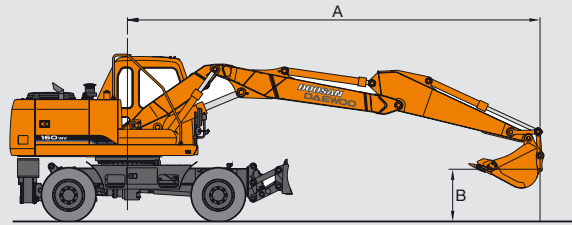

Centerline of rotation

Ground Line

Arti boom

Arm : 2,5 m

Bucket : SAE 0,58 m³ (CECE 0,55 m³)

Unit : 1.000 kg

Lifting conditions : Free on wheels / Dozer blade or Outriggers on ground

A(m)	2		3		4		5		6		7		8		Max. Reach		A(m)
	□	□□	□	□□	□	□□	□	□□	□	□□	□	□□	□	□□	□	□□	
B(m) 6							*2,97/*2,97	*2,97/*2,97	*2,57/*2,57	2,20/*2,57					*1,55/*1,55	*1,55/*1,55	6,58
5							*3,27/*3,27	2,99/*3,27	*3,07/*3,07	2,18/*3,07					*1,52/*1,52	*1,52/*1,52	7,13
4					*4,08/*4,08	*4,08/*4,08	*3,70/*3,70	2,89/*3,70	*3,47/*3,47	2,13/*3,47					*1,52/*1,52	1,40/*1,52	7,50
3					*5,08/*5,08	3,90/*5,08	*4,27/*4,27	2,76/*4,27	*3,80/*3,80	2,06/*3,69					*1,56/*1,56	1,31/*1,56	7,72
2					*6,13/*6,13	3,65/*6,13	*4,88/*4,88	2,62/*4,81	3,94/*4,17	1,98/*3,60					*1,63/*1,63	1,26/*1,63	7,81
1			*4,13/*4,13	*4,13/*4,13	*6,96/*6,96	3,46/*6,72	5,18/*5,41	2,50/*4,68	3,85/*4,51	1,90/*3,52					*1,74/*1,74	1,25/*1,74	7,77
0			*4,52/*4,52	*4,52/*4,52	7,45/*7,47	3,34/*6,57	5,08/*5,79	2,42/*4,58	3,79/*4,76	1,85/*3,46					*1,90/*1,90	1,28/*1,90	7,59
-1			*5,81/*5,81	5,11/*5,81	7,38/*7,63	3,29/*6,51	5,02/*5,96	2,38/*4,53	3,75/*4,86	1,82/*3,43					*2,13/*2,13	1,37/*2,13	7,28
-2			*7,79/*7,79	5,15/*7,79	7,38/*7,46	3,29/*6,51	5,01/*5,87	2,37/*4,52	3,75/*4,75	1,82/*3,43					*2,50/*2,50	1,53/*2,50	6,80
-3			*9,02/*9,02	5,23/*9,02	*6,91/*6,91	3,34/*6,57	5,05/*5,44	2,40/*4,56	3,80/*4,20	1,86/*3,48					*3,14/*3,14	1,82/*3,14	6,11

OPTION

Arti boom

Arm : 2,1 m

Bucket : SAE 0,39 m³ (CECE 0,35 m³)

Unit : 1.000 kg

Lifting conditions : Free on wheels / Dozer blade or Outriggers on ground

A(m)	2		3		4		5		6		7		8		Max. Reach		A(m)
	□	□□	□	□□	□	□□	□	□□	□	□□	□	□□	□	□□	□	□□	
B(m) 7							*2,59	*2,59							*2,31	*2,31	5,12
6							*3,49	*3,49							*2,21	*2,21	5,98
5							*3,69	*3,69	*3,47	*3,47					*2,20	*2,20	6,58
4			*5,63	*5,63	*4,64	*4,64	*4,11	*4,11	*3,81	*3,81					*2,24	*2,24	6,98
3			*7,68	*7,68	*5,62	*5,62	*4,65	*4,65	*4,11	3,74	*3,18	2,92			*2,33	*2,33	7,22
2					*6,60	*6,60	*5,22	4,85	*4,44	3,66	*3,82	2,88			*2,47	*2,47	7,31
1					*7,31	6,73	*5,69	4,72	*4,74	3,58	*4,09	2,84			*2,68	*2,68	7,27
0			*5,00	*5,00	*7,67	6,62	*5,98	4,64	*4,93	3,53	*3,54	2,82			*2,99	2,77	7,08
-1	*4,09	*4,09	*6,82	*6,82	*7,69	6,59	*6,05	4,61	*4,95	3,51					*3,47	2,98	6,74
-2			*9,41	*9,41	*7,37	6,61	*5,85	4,62	*4,69	3,53					*4,28	3,36	6,22
-3					*6,63	*6,63	*5,20	4,69							*4,57	4,12	5,46

Note 1. Ratings are based on SAE J1097

2. Load point is the hook on the back of the bucket

3. * = Rated loads are based on hydraulic capacity

4. Rated loads do not exceed 87% of hydraulic capacity or 75% of tipping capacity



: Rating over front



: Rating over side or 360 degree



: Ground



DAEWOO becomes DOOSAN

On the 29th of April 2005, the DOOSAN group acquired DAEWOO Heavy Industries & Machinery.

By taking this action, Doosan – with estimated sales of € 9 billion in 2005 and a workforce of 23,000 – is firmly consolidating its position among the ever smaller number of heavy equipment manufacturers around the world.

The company, now a major player with regard to industrial and public-sector infrastructure projects, is looking decisively towards the future with its advanced technologies and its investments in research and development.

The group's strengths are built on over 100 years of experience, & a solid financial structure, allowing it to commit to large-scale investments for ensured future success.

DOOSAN Infracore intends to become a worldwide leader in offering total industrial solutions to its clients.

Thierry Deschamps : "Our aim is to become a targeted "total service provider" by developing and integrating a range of different activities above and beyond our main area of work. The DOOSAN Infracore group's resources and expertise will allow us to move forward and broaden the portfolio of products and services we offer."

Doosan Infracore Europe S.A.

1^A, rue Achille Degrâce
7080 Frameries
Belgium
Tel : +32-65-61 32 30 • Fax : +32-65-67 73 38

Doosan Infracore France S.A.

1/3 rue Pavlov, Z.A. des Bruyères
78190 Trappes, France
Tel : +33-1-30 16 21 41 • Fax : +33-1-30 16 21 44

Doosan Infracore U.K., Ltd.

Doosan House, Unit 6.3, Nantgarw Park
Cardiff CF47QU, U.K.
Tel : +44-1443-84-2273 • Fax : +44-1443-84-1933

Doosan Infracore Germany GmbH

Hans-Böckler-Str. 29
D-40764, Langenfeld-Fuhrkamp, Germany
Tel : +49-2173-8509-18 • Fax : +49-2173-8509-45

Seoul Head Office

Doosan Tower 26th FL. 18-12, Euljiro-6Ga,
Jung-Gu, Seoul, Korea 100-730
Tel : +82-2-3389-8114 • Fax : +82-2-3389-8117



The illustrations do not necessarily show the product in standard version. All products and equipments are not available in all markets. Materials and specifications are subjects to change without prior notice.